

**FOR LIGHT COMMERCIAL TIPPING  
TRAILERS UP TO 3.5T GVM**

PART: 46401

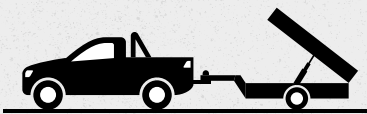

### Perfect for:

Operators who need clear visibility  
of the tipping location.

### Features:

- › Wired umbilical controller
- › 2 x wireless key fob controls
- › Hardened chromed tubes
- › Easy to service
- › Steel stop faces
- › Displacement cylinder
- › Polyurethane high pressure seals
- › Operating pressure of 160 bar, 2300psi
- › Wiper-scraper seals

### Kit contents:

- › Power Pack DC12V, 1.6KW, 2.5CC/R
- › Wired controller
- › 2 x wireless remote controllers
- › Ram 3 Stage, 1050mm Bottom Trunnion Mount 5T
- › 2 x Galvanized Deck Pads
- › Top Pin Kit for Ram
- › Ram Support Bracket
- › 2 x Top Mount for Ram

GET IN TOUCH

**0800 653 246**  
treadway.co.nz

## Dimensions, Specifications and Kit contents

PART: 46401

### POWER PACK

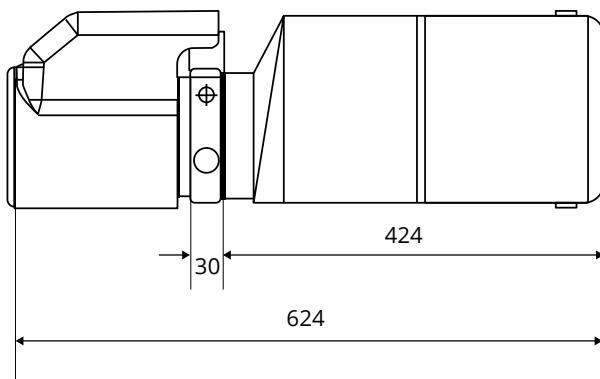

### BOTTOM TRUNNION MOUNT

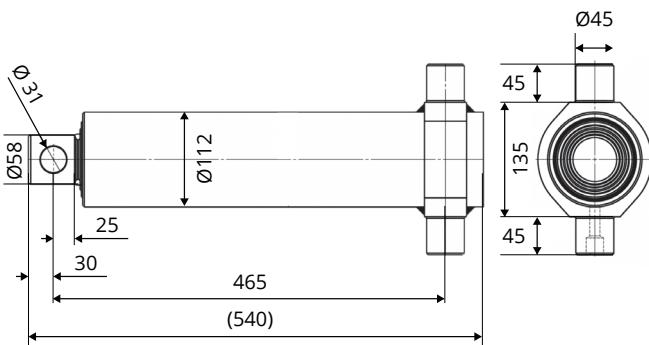

### Kit contents:

- › Power Pack DC12V, 1.6KW, 2.5CC/R
- › Wired controller
- › 2 x wireless remote controllers
- › Ram 3 Stage, 1050mm Bottom Trunnion Mount 5T
- › 2 x Galvanized Deck Pads
- › Top Pin Kit for Ram
- › Ram Support Bracket
- › 2 x Top Mount for Ram

### Specifications:

Load capacity	5000kg		
Operating pressure	160 bar, 2300psi		
Stroke length	1050mm		
Oil tank	10L		
Stages	3		
Cylinder Dimensions (external)	96	80	65
Rod Dimensions	92	75	60
Part	46401		



### 100% NZ FAMILY OWNED AND OPERATED

We've been in business for over 40 years. In that time we have come to supply some of NZ's major trailer and farm equipment manufactures with Trailer Kits & Parts, Wheels, Rims and Tyres.

GET IN TOUCH

**0800 653 246**  
treadway.co.nz